

Forest 3000 Impala back loading

IMPALA BACK LOADING

Nuovo mobile a caricamento posteriore, ideale per le petrol station, dotato di porte posteriori scorrevoli. Disponibile nella versione con carrelli (trolley version) e nella versione con ripiani (shelves version). Un apposito kit consente di trasformare facilmente il mobile dalla versione con carrelli alla versione con ripiani.

IMPALA BACK LOADING

New cabinet to be loaded from the back, ideal for petrol stations and equipped with rear sliding doors. Available in two versions: with trolleys (trolley version) or shelves (shelves version). By the use of an ad-hoc kit the trolley version can easily be converted into the shelf version.



Impala back loading
H20-22 Shelves

Impala back loading		188	250	375
Lunghezza (senza spalle) Length (without ends) Longueur (sans joues) Länge (ohne Seitenteile) Longitud (sin los laterales) Comprimento (sem lateral)	Shelves Version	H2240	●	●
		H2440	●	●
	Trolley Version	H2240	●	●
		H2440	●	●
Superficie d'esposizione Display area Surface d'exposition Auslagefläche Superficie expositiva Superficie exposição	Shelves Version	H2240	4,33	6,50
		H2440	4,83	7,25
	Trolley Version	H2240	3,25	4,33
		H2440	3,62	4,83
Spessore spalla - End thickness Épaisseur de chaque joue - Stärke des Seitenteile Espesor lateral - Espessura da lateral		3,5		

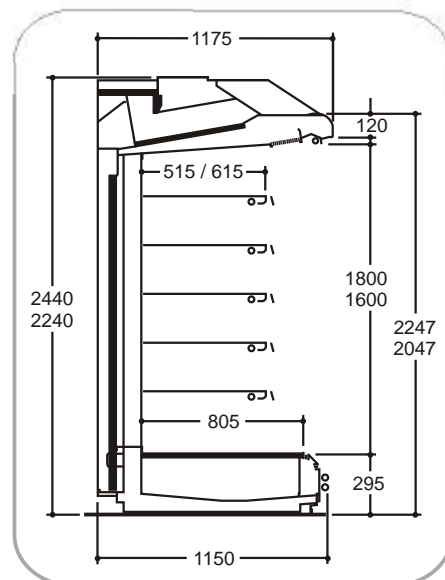

IMPALA BACK LOADING

Nouveau meuble à chargement postérieur, idéal pour les stations essence, équipé de portes postérieures coulissantes. Disponible dans la version avec chariots (version trolley) et dans la version avec étagères (version shelves). Un kit prévu à cet effet permet de transformer facilement le meuble de la version avec chariots à la version avec étagères.

IMPALA BACK LOADING

Nuevo mueble para cargar por detrás, ideal para estaciones de servicio y equipado con puertas traseras corredizas. Disponible en dos versiones: con carros (trolley version) o con estantes (shelves version). Por medio del kit correspondiente es posible transformar con facilidad la versión con carros en la versión con estantes.



Impala back loading Trolley



Impala back loading Shelves

Impala back loading
H20-22 Trolley

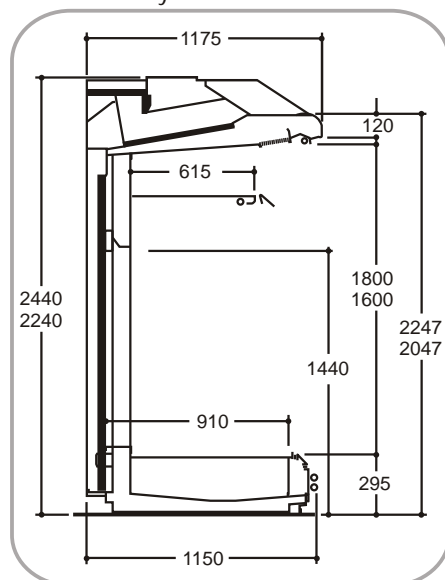

IMPALA BACK LOADING

Neues Möbel, das an der Rückseite mit Schiebetüren versehen ist und von hinten beschickt wird und sich deshalb bestens für den Einsatz in Tankstellen eignet. Es ist in der Ausführung mit Beschickungswagen ("trolley version") und in der Ausführung mit Auslagenfächern ("shelves version") erhältlich. Mit Hilfe eines speziellen Bausatzes kann die Trolley -Ausführung einfach in eine Shelves-Version umgebaut werden.

IMPALA BACK LOADING

Novo móvel de carga posterior, ideal para as petrol station, dotado de portas posteriores de correr. Disponível na versão com carros (trolley version) e na versão com prateleiras (shelves version). Um kit apropriado permite de transformar facilmente o móvel da versão com carros à versão com prateleiras.

